



# Extended Range Tubing Cutter for 2.875 and 3.500 in. Tubing

**MAN-REC-XTC (R04)**

## **OWEN OIL TOOLS**

12001 Cr 1000  
Godley, Texas, 76044, USA  
Phone: +1 (817) 551-0540  
Fax: +1 (817) 551-1674  
[www.corelab.com/owen](http://www.corelab.com/owen)

**Warning:** use of owen equipment contrary to manufacturer's specifications or operating instructions may result in property damage, serious injury or fatality. If you are not trained in the handling and use of explosive devices, do not attempt to use or assemble any owen perforating systems or owen firing devices.

This technology is regulated by and, if exported, was exported from the united states in accordance with the export administration regulations (EAR). Diversion contrary to U.S. Law is prohibited. Export and/or re-export of this technology may require issuance of a license by the bureau of industry and security (BIS), U.S. Department of Commerce. Consult the BIS, the EAR, and/or Owen Compliance Services, Inc. To determine licensing requirements for export or re-export of this technology.

This document contains confidential information of Owen Oil Tools LP (Owen) and is furnished to the customer for information purposes only. This document must not be reproduced in any way whatsoever, in part or in whole, or distributed outside the customer organization, without first obtaining the express written authorization of owen. This document is the property of owen and returnable upon request of Owen.



# Extended Range Tubing Cutter For 2.875 and 3.500 in. Tubing

## Range Overview

### Description

Extended Range Tubing Cutters are designed for use in Pipe Recovery Operations as a final solution. The cutter is undersized to get through tight restrictions where a conventional cutter is not an option.

### Operation

Extended Range Tubing Cutters provide a quick and effective solutions to sever tubing. Extended Range Tubing Cutters utilize unique manufacturing and packaging processes to allow easy shipment and fast delivery to the customer.

Extended Range Tubing Cutters should be used when restrictions prohibit the use of conventional tubing cutters. The cutter with the largest possible diameter capable of running in the well should be chosen to achieve maximum performance. A gauge run is recommended prior to running the tool to insure the cutter can get to proper depth. This will prevent any safety concerns like sticking a live cutter in the well or spudding with explosive tools. Extended Range Tubing Cutters are to be shot in the tubing above the stuck point, but not at the collar. To maintain the maximum allowable performance from the cutter, it should be centralized. A de-centralized cutter may result in a partial cut and/ or damage to the casing. It is also recommended that tension be applied to the tubing prior to detonation of the Tubing Cutter to assist in the removal of stuck tubulars.

Extended Range Tubing Cutters utilize explosive technology and are designed to explosively sever tubular members when initiated by an Owen's Resistorized Bridge™ Detonator. Owen's electrical detonators adhere to API RP-67 specifications. All safety rules and regulations should be strictly followed when storing, handling, assembling, and using these cutters and/or detonators. Safety precautions should be taken in accordance with your company's safety policies, governmental regulations, and the American Petroleum Institute Recommended Practice 67 (API RP-67).

Extended Range Tubing Cutters come standard with HMX explosive powder rated to 400° F (204° C) for 1 hour.



# Extended Range Tubing Cutter For 2.875 and 3.500 in. Tubing

## Specifications

OUTER DIA. [IN (MM)]	TEMP. [°F (°C)]	PRESSURE [PSI (MPA)]	EXPLOSIVE WEIGHT [LB (KG) (G)]	RECOMMENDED APPLICATION	PART NUMBER
1.875 (47.6)	400 (204)	15,000 (103.4)	.032 (.015) (15)	2.875"	6.5# - 8.7# CUT-1875-419
2.188 (55.6)	400 (204)	15,000 (103.4)	.064 (.029) (29)	3.500"	9.3# - 12.95# CUT-2188-419
1.687 (42.9)	400 (204)	5,000 (34.5)	.04 (.019) (19)	2.875"	6.5# - 8.7# CUT-1687-429

## Recommended Practices

A minimum of two bowspring centralizers should be run as a part of the tool string to insure adequate centralization of the cutter at depth. Owen recommends the 1 11/16" Bowspring Centralizer from Applied Electronic Systems, part number AS6-0066 (Owen part number AES-AS60066).

# Extended Range Tubing Cutter For 2.875 and 3.500 in. Tubing

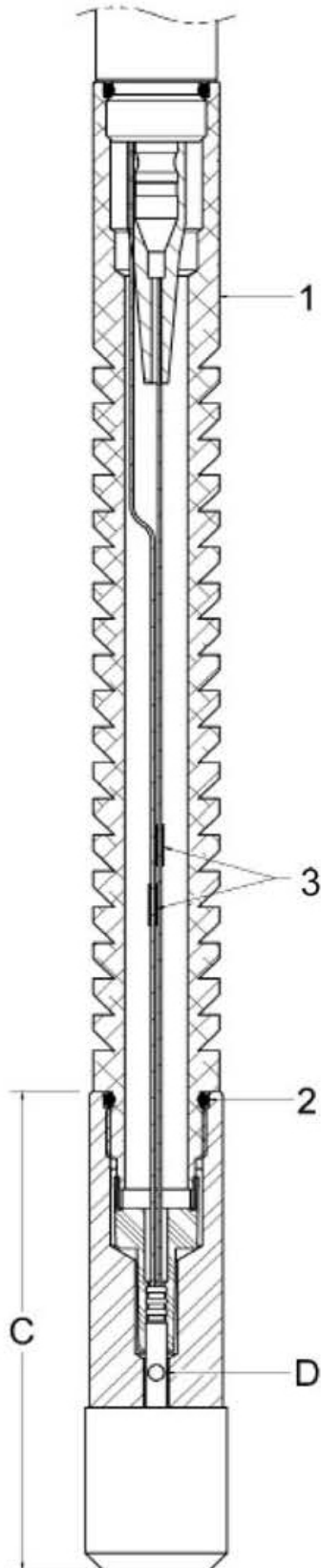

ITEM	DESCRIPTION	PART NUMBER
1	Aluminum Shock Sub - Open Bore	CUT-0100-079
	Steel Extension adapter	CUT-0100-087
2	O-Ring for Adapter	OOO-V569-214
3	Splice Boot	PUR-0210-001
C	1.875" Tubing Cutter	CUT-1875-419
D	Detonator	DET-3050-009L
--	RP-67 Arming Shield (Not Shown)	CUT-1687-046
--	Shunt Plug (Not Shown)	CUT-0100-016

- Item 1 - 3 and detonator must be ordered separately from cutter assembly.
- Alternate arming assembly available, using JRC style extension adapter with button contacts, CUT-0100-078 and detonator with spring contacts, DET-3050-009E for 1.56" and larger cutters.
- Owen recommends running a minimum of two bowsprings centralizers with these tubing cutters. The recommended part number for this 1.687" Bowspring Centralizer is AES- AS60066-6.
- ACE™ Extended Range Cutter is not intended to replace standard cutter application.

# Extended Range Tubing Cutter For 2.875 and 3.500 in. Tubing

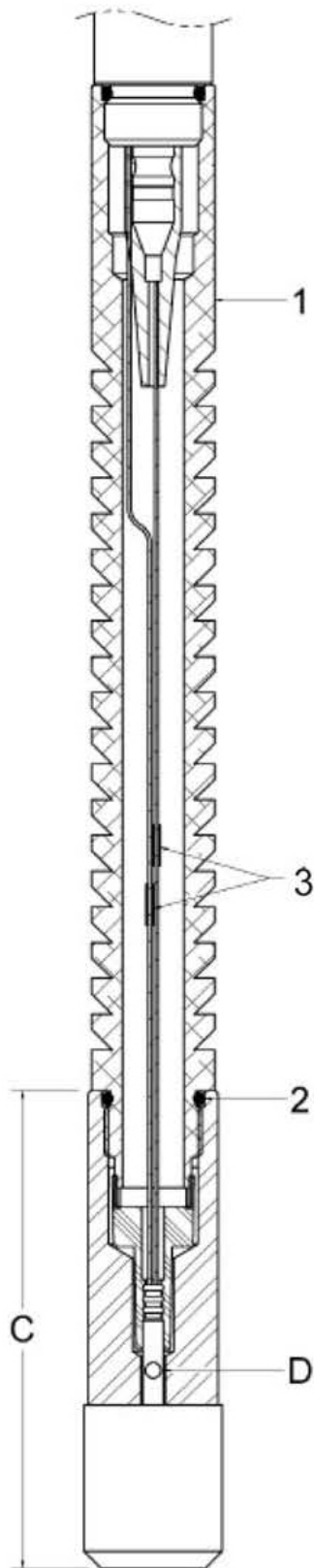

ITEM	DESCRIPTION	PART NUMBER
1	Aluminum Shock Sub - Open Bore	CUT-0100-079
	Steel Extension adapter	CUT-0100-087
2	O-Ring for Adapter	OOO-V569-214
3	Splice Boot	PUR-0210-001
C	2.188" Tubing Cutter	CUT-2188-419
D	Detonator	DET-3050-009L
--	RP-67 Arming Shield (Not Shown)	CUT-2062-046
--	Shunt Plug (Not Shown)	CUT-0100-016

- Item 1 - 3 and detonator must be ordered separately from cutter assembly.
- Alternate arming assembly available, using JRC style extension adapter with button contacts, CUT-0100-078 and detonator with spring contacts, DET-3050-009E for 1.56" and larger cutters.
- Owen recommends running a minimum of two bowsprings centralizers with these tubing cutters. The recommended part number for this 1.687" Bowspring Centralizer is AES- AS60066-6.
- ACE™ Extended Range Cutter is not intended to replace standard cutter application.

## 1.0 Assembly and Arming of Tubing Cutter Using DET-3050-009L



**Warning:** Always follow API RP-67 guidelines when arming electrical detonators!

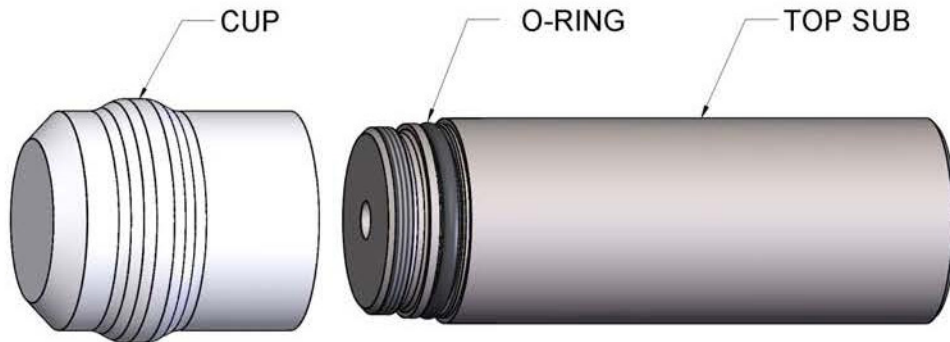

Figure 1: Exploded Assembly View of Tubing Cutter

CUTTER PART #	O-RING
CUT-1687-429	218
CUT-1875-419	218
CUT-2188-419	223



**Note:** The Tubing Cutter will normally be shipped assembled, but must be disassembled to install the O-ring and to arm the tool.

- 1.1 Visually inspect the O-ring for cuts or cracks and lightly lubricate it with grease.
- 1.2 Install the O-ring onto the top Sub as shown in Figure 1.
- 1.3 Thread the cup retaining the explosive cutter load onto the bottom of the Top Sub. Make sure the cup shoulders out on the Top Sub and the O-ring seal is sufficiently formed. Make sure the finger spring washer is installed as shown in Figure 2. It does not matter if the fingers on the spring are pointing up or down.



Figure 2: Finger Spring Washer Installation



**Note:** *The Tubing Cutter Cartridges and Booster are pre assembled and inside the cutter Cup.*

- 1.4 Remove the detonator from its package.
- 1.5 Insert the detonator into a safety shield.
- 1.6 Measure the resistance of the detonator between the two lead wires with a blaster's multimeter. The detonator should read 51 Ohms  $\pm$  5 Ohms.
- 1.7 Remove the O-ring from package. Inspect it visually for cuts or cracks. Lightly lubricate the O-ring with grease.
- 1.8 Install the O-ring onto the Extension Adapter.

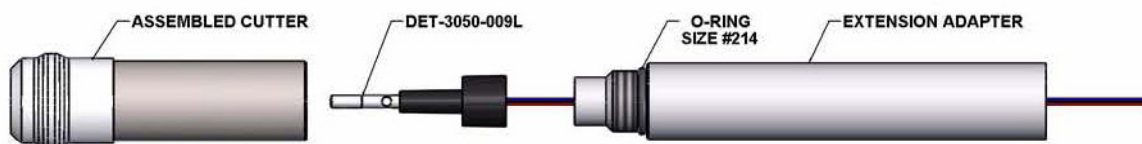

Figure 3: Exploded Arming View of Tubing Cutter Using DET-3050-009L

- 1.9 Insure the wireline is shunted through shooting panel.

- 1.10 Insert the detonator lead wires through the hole in the Extension Adapter.
- 1.11 Electrically connect the detonator lead wires to the wireline or toolstring.
- 1.12 Mechanically connect the Extension Adapter to the wireline toolstring.
- 1.13 Remove the detonator from the safety shield and install the booted portion of the detonator over the end of the Extension Adapter.
- 1.14 Thread the Top Sub onto the Extension Adapter with the detonator fitting inside the bore of the Top Sub.
- 1.15 The tool is armed and ready to run in hole.

## 2.0 Assembly and Arming of Tubing Cutter Using DET-3050-009E



**Warning:** Always follow API RP-67 guidelines when arming electrical detonators.

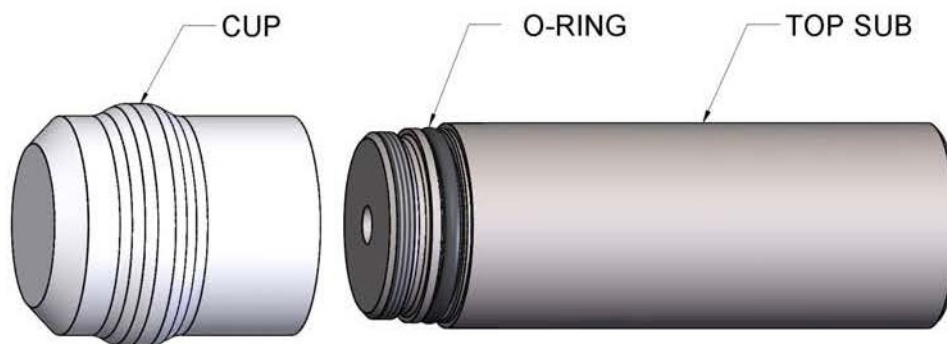

Figure 4: Exploded Assembly View of Tubing Cutter

CUTTER PART #	O-RING
CUT-1687-429	218
CUT-1875-419	218
CUT-2188-419	223



**Note:** The Tubing Cutter will normally be shipped assembled, but must be disassembled to install the O-ring and to arm the tool.



- 2.1 Visually inspect the O-ring for cuts or cracks and lightly lubricate it with grease. Make sure the Cup that retains the explosive cutter load is removed from the Top Sub (item #1).



**Note:** *The Tubing Cutter Cartridges and Booster are pre-assembled and inside the cutter Cup.*

- 2.2 Remove the detonator from its package, disconnect the ground wire from the spring and wrap it around the rubber sleeve of the detonator. The detonator will still be shunted because the temporary shunt has not been removed.



**Note:** *Refer to the 009 Cutter Detonator manual (MAN-DET-009) for more information about the proper use of the detonator.*

- 2.3 Thread the Shunt Plug into the Shock Sub with Contacts.

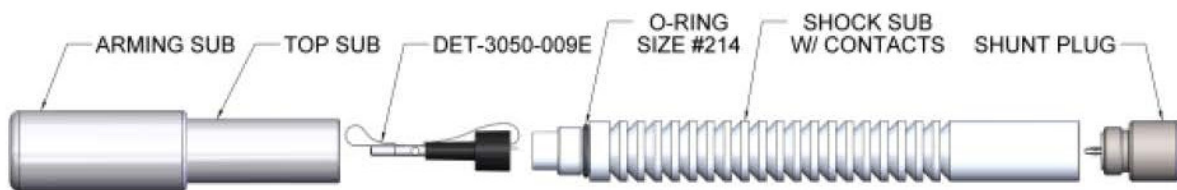

**Figure 5: Exploded Arming View of Tubing Cutter Using DET-3050-009E**

- 2.4 Install the detonator onto the bottom nose of the Shock Sub with Contacts so that the detonator's rubber boot fits snug around the nose. Take caution not to roll the rubber boot and disrupt the contact between the detonator and internal contact of the Shock Sub with Contacts.
- 2.5 With the system shunted by the Shunt Plug, remove the temporary shunt wire from the detonator.
- 2.6 Install the Arming Sub onto the Top Sub
- 2.7 Make sure the #214 O-ring is lightly lubricated with grease and install the Shock Sub with Contacts with the detonator installed on the nose into the top end of the Top Sub, detonator first.

- 2.8 Now that the detonator is safely contained within the Arming Sub, remove the Shunt Plug from the top end of the Shock Sub with Contacts.
- 2.9 Make sure the wireline is shunted and connect the Shock Sub with Contacts to the wireline. This will electrically connect the detonator to the wireline, while the detonator is still in the confined hardware.
- 2.10 Remove the Arming Sub.
- 2.11 Reapply a light coating of grease to the o-ring on the bottom of the Top Sub. Then, thread the cup retaining the explosive cutter load onto the bottom of the Top Sub. Make sure the cup shoulders out on the Top Sub and the o-ring seal is sufficiently formed. Make sure the finger spring washer is installed as shown in Figure 6. It doesn't matter if the fingers on the spring are pointing up or down.
- 2.12 The tool is armed and ready to run in hole.



Figure 6: Finger Spring Washer Installation

### 3.0 Frequently Asked Questions

#### 3.1 What grades of tubing can this tubing cutter cut?

- The ACE Extended Range Tubing Cutter Product Line, is capable of cutting all material grades ranging from J-55 up to P-110 as well as 13Cr and 22Cr tubular. The chrome grades should range from 80 grade up to 110 grade.