



Mechanical Firing Head Econo Style

TC-011-2375-000

TC-011-2875-000

TC-011-3500-000

MAN-TC-011 (R08)

Owen Oil Tools

5405 Blindman Crescent
Red Deer County Alberta Canada T4S 2B3
Phone: 1-403-340-1017
Fax: 1-403-340-1415
Toll Free: 1-888-345-1017
www.owentools.com

Warning: Use of Owen equipment contrary to manufacturer's specifications or operating instructions may result in property damage, serious injury or fatality. If you are not trained in the handling and use of explosive devices, do not attempt to use or assemble any Owen perforating systems or Owen firing devices.

Owen Oil Tools pre-assembles its tools as per the field operating manual. It is the responsibility of the purchaser to insure that this tool is assembled as required, prior to use.

This technology is regulated by and, if exported, was exported from the United States in accordance with the Export Administration Regulations (EAR). Diversion contrary to US Department of Commerce. Consult the BIS, the EAR and/or Owen Compliance Services, Inc. to determine licensing requirements for export or re-export of this technology.

This document contains Confidential information of Owen Oil Tools LP (Owen) and is furnished to the customer for information purposes only. This document must not be reproduced in any way whatsoever, in part or in whole, or distributed outside the customer organization, without first obtaining the express written authorization of Owen. This document is the property of Owen and returnable upon request by Owen.

©2009 Owen Oil Tools

Blank Page

Description

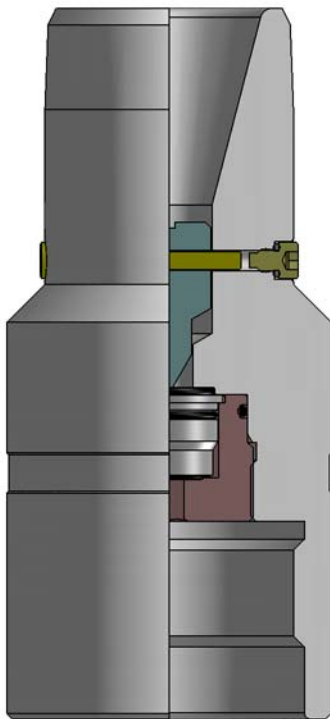

The Mechanical Firing Head is an economical TCP Firing Head which allows detonation of the gun system by releasing a Slim Nose Drop Bar into the tubing from surface. The Firing Pin is held in the bore of the Firing Head with a Shear Pin which is severed upon impact of the Slim Nose Drop Bar, allowing the Firing Pin to travel downward. The percussion transmitted to the Initiator causes detonation which is transferred to the Gun System.

The Firing Head is designed to use the CP Percussion Initiator. The Initiator is retained in the bottom of the Firing Head with an Initiator Retaining Nut which allows the Firing Head to be transported safely without any explosives installed. The top of the Firing Head features standard 8RD EUE Pin connections to thread into the tubing string as well as an integral No-Go profile which ensures that foreign objects do not accidentally fire the guns.

Features and Benefits

- Connects directly to any gun system top sub with GO 2.750 Acme thread
- CP Percussion Initiator contains no lead azide and maintains differential pressure integrity even after detonation
- Allows easy handling on the rig floor
- Ensures that the Initiator may not be installed incorrectly, reducing the possibility of a misrun
- Integral No-Go feature ensures that foreign objects dropped into the tubing may not detonate the gun. Initiator may be installed at the rig so the Firing Head is not transported with explosives installed
- May be used in snubbing applications
- At least one full tubing joint filled with fluid directly on top of the Firing Head is recommended for optimum drop bar impact

Note:

this Mechanical Firing Head does not comply with API-RP-67, Section 6.4.2. This tool should only be used when no other tool will satisfy job requirements and a procedure has been established to prevent accidental

	2-3/8 in (60.3 mm)		2-7/8 in (73.0 mm)		3-1/2 in (88.9 mm)	
Maximum OD	3.375 in	85.7 mm	3.375 in	85.7 mm	4.500 in	114.0 mm
Minimum ID	0.875 in	22.2 mm	0.875 in	22.2 mm	0.875 in	22.2 mm
Overall Length	7.4 in	188 mm	7.8 in	198 mm	8.8 in	223 mm
Max Pressure ²	20,000 psi	137.9 MPa	20,000 psi	137.9 MPa	20,000 psi	137.9 MPa
Tensile	55,200 lb	24 550 daN	79,400 lb	35 300 daN	90,400 lb	40 200 daN
Max Temp ¹	250°F (121°C)					
Connections	2-3/8 in (60.3 mm) EUE Pin GO 2.750 ACME Box		2-7/8 in (73.0 mm) EUE Pin GO 2.750 ACME Box		3-1/2 in (88.9 mm) EUE Pin GO 2.750 ACME Box	
Product Number	TC-011-2375-000		TC-011-2875-000		TC-011-3500-000	
Redress Kit	TC-011-2375-099		TC-011-2875-099		TC-011-3500-099	

¹The maximum temperature can be increased to 450° (230°C) by substituting the 90 durometer Nitrile O-rings with 90 durometer Viton O-rings. Refer to the Time vs Temperature chart for Explosives to confirm any explosives requirements

²The maximum pressure is determined by the maximum allowable pressure differential of Initiator

Mechanical Firing Head
Econo Style

MAN-TC-011

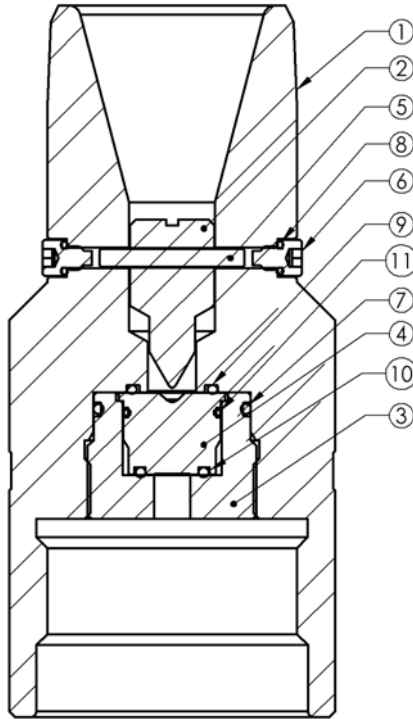

Item	Part Number	Qty	Description
--	TC-011-2375-000	--	Mechanical Firing Head 2-3/8" EU
1	TC-011-0000-000	1	Firing Head Body 2-3/8" EU
2	TC-011-0001-000	1	Firing Pin f/Mechanical Firing Head
3	TC-011-0002-000	1	Initiator Retaining Nut
4	Reference	1	Percussion Detonator
5	PF-100-0188-150B	1	Brass Shear Pin (OD 0.188", 1.50 LG)
6	SF-050-025F-050S	2	Shear Screw 1/4" - 28 UNF x 0.5 LG.
7	OOO-N569-127	1	O-Ring 90 Durometer Nitrile
8	OOO-N569-009	2	O-Ring 90 Durometer Nitrile
9	OOO-N569-116	1	O-Ring 90 Durometer Nitrile
10	OOO-N569-113	1	O-Ring 90 Durometer Nitrile
11	OOO-N569-020	1	O-Ring 90 Durometer Nitrile
---	PF-074-0000-000	1	Tube Nut P/N TN-66
---	TC-011-2375-098	1	Redress Kit for Mechanical Firing Head 2-3/8" EU (without Firing Pin)
---	TC-011-2375-099	1	Redress Kit for Mechanical Firing Head 2-3/8" EU
---	MAN-TC-011	1	Assembly Manual

Item	Part Number	Qty	Description
--	TC-011-2875-000	--	Mechanical Firing Head 2-7/8" EU
1	TC-011-0003-000	1	Firing Head Body 2-7/8" EU
2	TC-011-0001-000	1	Firing Pin f/Mechanical Firing Head
3	TC-011-0002-000	1	Initiator Retaining Nut
4	Reference	1	Percussion Detonator
5	PF-100-0188-150B	1	Brass Shear Pin (OD 0.188", 1.50 LG)
6	SF-050-025F-050S	2	Shear Screw 1/4" - 28 UNF x 0.5 LG.
7	OOO-N569-127	1	O-Ring 90 Durometer Nitrile
8	OOO-N569-009	2	O-Ring 90 Durometer Nitrile
9	OOO-N569-116	1	O-Ring 90 Durometer Nitrile
10	OOO-N569-113	1	O-Ring 90 Durometer Nitrile
11	OOO-N569-020	1	O-Ring 90 Durometer Nitrile
---	PF-074-0000-000	1	Tube Nut P/N TN-66
--	MAN-TC-011	1	Assembly Manual
--	TC-011-2375-098	1	Redress Kit, Mechanical Firing Head 2-7/8" EU (without Firing Pin)
--	TC-011-2375-099	1	Redress Kit for Mechanical Firing Head 2-7/8" EU

Item	Part Number	Qty	Description
--	TC-011-3500-000	--	Mechanical Firing Head 3-1/2" EU
1	TC-011-0004-000	1	Firing Head Body 3-1/2" EU
2	TC-011-0001-000	1	Firing Pin f/Mechanical Firing Head
3	TC-011-0002-000	1	Initiator Retaining Nut
4	Reference	1	Percussion Detonator
5	PF-100-0188-150B	1	Brass Shear Pin (OD 0.188", 1.50 LG)
6	SF-050-025F-050S	2	Shear Screw 1/4" - 28 UNF x 0.5 LG.
7	OOO-N569-127	1	O-Ring 90 Durometer Nitrile
8	OOO-N569-009	2	O-Ring 90 Durometer Nitrile
9	OOO-N569-116	1	O-Ring 90 Durometer Nitrile
10	OOO-N569-113	1	O-Ring 90 Durometer Nitrile
11	OOO-N569-020	1	O-Ring 90 Durometer Nitrile
---	PF-074-0000-000	1	Tube Nut P/N TN-66
--	MAN-TC-011	--	Assembly Manual
--	TC-011-2375-098	--	Redress Kit, Mechanical Firing Head 3-1/2" EU (without Firing Pin)
--	TC-011-2375-099	--	Redress Kit for Mechanical Firing Head 3-1/2" EU

Part Number	Qty	Description
TC-011-2375-098	--	Redress Kit for Mechanical Firing Head 2-3/8", 2-7/8", & 3-1/2" EU (without Firing Pin)
OOO-N569-020	1	O-Ring 90 Durometer Nitrile
OOO-N569-113	1	O-Ring 90 Durometer Nitrile
OOO-N569-116	1	O-Ring 90 Durometer Nitrile
OOO-N569-127	1	O-Ring 90 Durometer Nitrile
PF-074-0001-000	1	Tube Nut P/N TN-66
PF-100-0188-150B	1	Brass Shear Pin (OD 0.188", 1.50 LG)
OOO-N569-009	2	O-Ring 90 Durometer Nitrile
SF-050-025F-050S	2	Shear Screw 1/4" - 28 UNF x 0.5 LG.

Part Number	Qty	Description
TC-011-2375-099	--	Redress Kit for Mechanical Firing Head 2-3/8", 2-7/8" & 3-1/2" EU
OOO-N569-020	1	O-Ring 90 Durometer Nitrile
OOO-N569-113	1	O-Ring 90 Durometer Nitrile
OOO-N569-116	1	O-Ring 90 Durometer Nitrile
OOO-N569-127	1	O-Ring 90 Durometer Nitrile
PF-074-0001-000	1	Tube Nut P/N TN-66
PF-100-0188-150B	1	Brass Shear Pin (OD 0.188", 1.50 LG)
TC-011-0001-000	1	Firing Pin f/Mechanical Firing Head
OOO-N569-009	2	O-Ring 90 Durometer Nitrile
SF-050-025F-050S	2	Shear Screw 1/4" - 28 UNF x 0.5 LG.

Note: Redress Kits, TC-011-2375-098 and TC-011-2375-099 are not included

Note: Before assembling the Mechanical Firing Head, ensure that all components are present (refer to the Exploded View at the end of the manual). Inspect all parts carefully for any signs of wear, thread galling, machining defects or damage. All of the parts should be cleaned thoroughly before attempting any assembly of the Firing Head.

It is important to check the Firing Pin travel to make sure that the Initiator will not be breached during impact of the Drop Bar. Before installing the Shear Pin, slide the Firing Pin fully into the Body until the Pin hits the internal shoulder. Measure the distance from the tip of the Firing Pin to the face of the Firing Head Body. This distance must be within the range 0.215 - 0.250 inch (5.46 - 6.35 mm). If it is not within this range, the Firing Pin must be replaced.

In order to ensure the proper operation of the Firing Head, the Firing Pin must be replaced after each detonation. The impact with the Initiator tends to shorten the Firing Pin and make the tapered end blunt.

Assembly

1. Install the Firing Pin (item 2) by sliding the Firing Pin, point first, into the main body (item 1). Align the hole through the body with the hole in the firing pin. Insert the Brass Shear Pin (Item 5) roughly to the center of the main body. Lightly grease and install O-rings (item 8) on the shear screws (item 6) and screw the shear screws into each side of the body.
2. Lightly grease and install O-ring (item 7) on Initiator Retaining Nut (item 3). The Nut can then be threaded into the Main Body (item 1). At this time, the Initiator (item 4) may be installed or left until the guns are run into the well and landed on the rig floor.
3. **Initiator Installation:** Lightly grease and install O-ring (item 11) on the Initiator (item 4) . To retain the O-rings (item 9 and 10) lightly grease and set them on top and bottom of Initiator as show in the exploded view.
Note: it critical that you do not use an excessive amount of grease on the bottom O-ring (item 10) as it may affect the detonation process.
Now lightly coat the inside of the Initiator Nut Retainer (item 3) and carefully press the Initiator into the Nut until the top of the Initiator flange is flush with the end of the Nut.

Caution: Do Not use any pointed device to drive the Initiator into the Initiator Nut, as this may cause detonation resulting in serious injury. Install by hand only with gentle pressure.

Now install the Nut with the Initiator into the Main Body. Make sure the end of the Retainer Nut is flush with the internal face of the Main Body.

Notes: it is good practice to insert the Initiator into the Main Body immediately before running the Firing Head into the well. This may be done easily in field conditions. Ensure that the perforating gun is configured so that the top shot is below the rig floor when installing the Mechanical Firing Head. **Do Not** install the Firing Head until the guns are in the hole and the top shot is located below the rig floor.

The Firing Head is now fully assembled and ready to be installed on the gun Top Sub. Install the appropriate O-rings and thread compound to the Top Sub and tighten the connection. Once tight, lower the tubing string onto the Firing Head Pin thread (EUE). After applying thread compound, make up the tubing connection on the Firing Head and run it into the well.

Econo Style

Running Procedures

Once the guns have been properly positioned on depth, drop the bar from surface to detonate the perforating guns. After the appropriate period has elapsed and there has been no indication of gun detonation, a second bar may be released, only after the first bar has been retrieved. However, it is highly recommended that no more than two bars be dropped. At this point, the perforating string may be retrieved.

Important:

In case of a misrun, the Drop Bar must be retrieved prior to removing the guns from the well. **Under no circumstances may the guns be removed from the well with Drop Bar left in place.**

When disassembling a Firing Head that has misfired, never push on the discharge end of the Initiator with a sharp or pointed object. A soft rubber piece may be used to remove the Initiator gently.

